

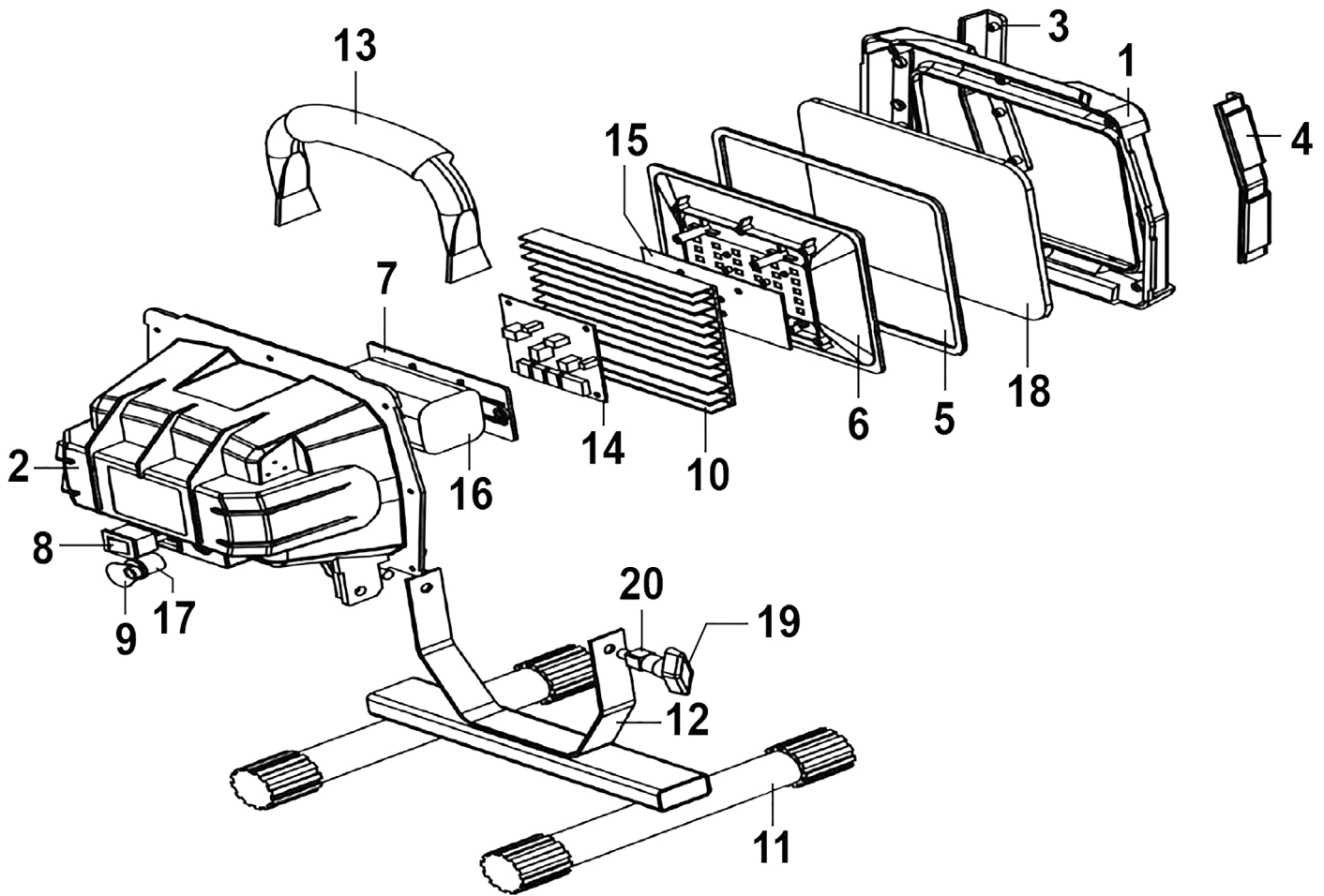

Parts Information:
**Rechargeable Portable Floodlight 10W
 SMD LED
 Model No: LED109C.V3**



Item	Part No.	Description
1	LED109C.V2-01	Front Housing
2	LED109C.V2-02	Back Housing
3	LED109C.V3-03	Side Strip, Left Side
4	LED109C.V3-04	Side Strip, Right Side
5	LED109C.V2-03	Sealing Ring
6	LED109C.V3-06	Led Reflector
7	LED109C.V3-07	Circuit Board Support
8	LED109C.V3-08	Switch, On/Off Rocker (13a/250v) T105/55
9	LED109C.V3-09	Charging Socket Cover
10	LED109C.V3-10	Aluminium Cover
11	LED109C.15	Steel Stand "H"
12	LED109C.14	Steel Base "U"

Item	Part No.	Description
13	LED109C.17	Handle
14	LED109C.V3-14	PCB, Circuit Board, 74 X 60mm
15	LED109C.V3-15	PCB, Circuit Board LED, 96 X 42mm, LED x 30
16	LED109C.V3-16	Battery, 7.4v, 4.4ah/32.5wh (Li-Ion)(H:70 W:37 B:37)
17	LED109C.V3-17	Charging Socket
18	LED109C.V2-04	Tempered Glass
19	LED109C.V3-19	Hand Bolt
20	LED109C.V3-20	Hand Nut
--	LEDPI2VIA	Mains Charger UK 12V DC 1000mA 5mm Pin Jack (Not Shown)
--	LED109C.V3-22	In-Car Charger 12V DC 5mm Pin Jack (Not Shown)

NOTE: It is our policy to continually improve products and as such we reserve the right to alter data, specifications and component parts without prior notice. There may be alternative versions of this product, please contact us should you require this information.

IMPORTANT: No liability is accepted for incorrect use of product. Spare parts must be fitted by a competent person

WARRANTY: Guarantee is 12 months from purchase date, proof of which will be required for any claim.

Sealey Group, Kempson Way, Suffolk Business Park, Bury St Edmunds, Suffolk. IP32 7AR



01284 757500



sales@sealey.co.uk



www.sealey.co.uk